

15A CORDEND GFCI  
30-0061

Temperature Sensor

High-Limit Sensor

33-0012-R1

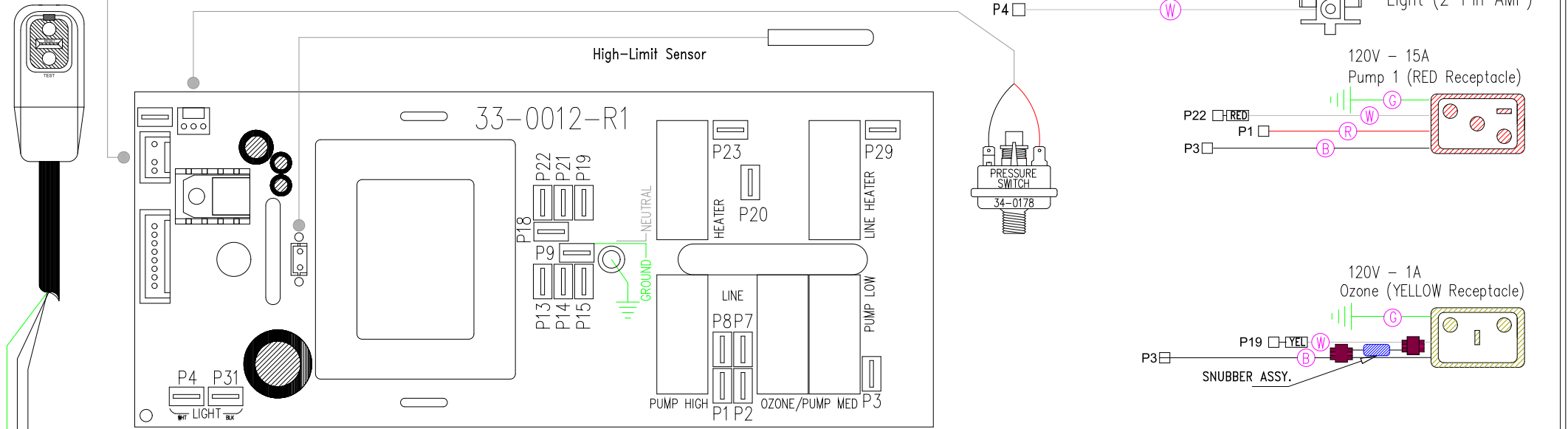

# 1

INCOMING POWER TERMINAL BLOCK

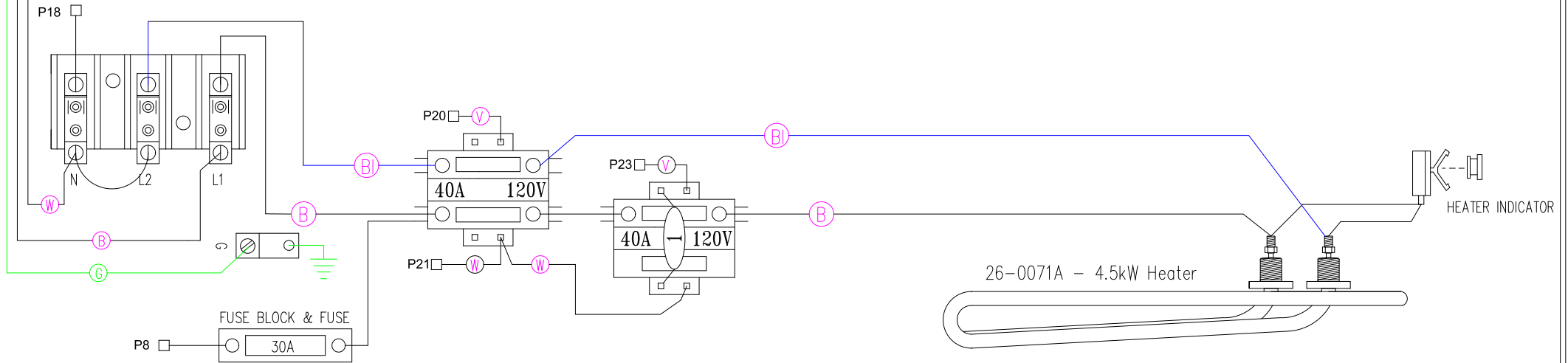

Manufacture Notes:

#1 - MAIN COMPONENT VOLTAGE CONVERSION DONE AT INCOMING TERMINAL BLOCK  
 #2 - FOR 240V OPERATION REMOVE JUMPER BETWEEN L2 AND N. CONNECT L1, L2, N, GROUND. ADJUST CURRENT LIMITING IN LLP TO "HC"

Drawn MBS	Rev 0	Wire Color Code B - Black      G - Green Br - Brown    Bl - Blue R - Red        V - Violet O - Orange    W - White Y - Yellow     Gr - Grey
Date 01.21.08		
Diagram No. 0634		